

MINI - VERTICUS II

THE COMPLETE UNIT

150 - 240 l/min



**Economical, silent and absolutely reliable !**

The sound-proofed MINI-VERTICUS II is the ideal partner for diving centers and diving shops, who count on reliable and long-life use coupled with low operating expenses.

Rapid spare parts supply and service guarantee a successful diving season - globally.

The patented P41 purification system guarantees purest breathing air quality acc. to **DIN EN 12021**, formerly DIN 3188.

## THE INNOVATIVE SYSTEM CONCEPT

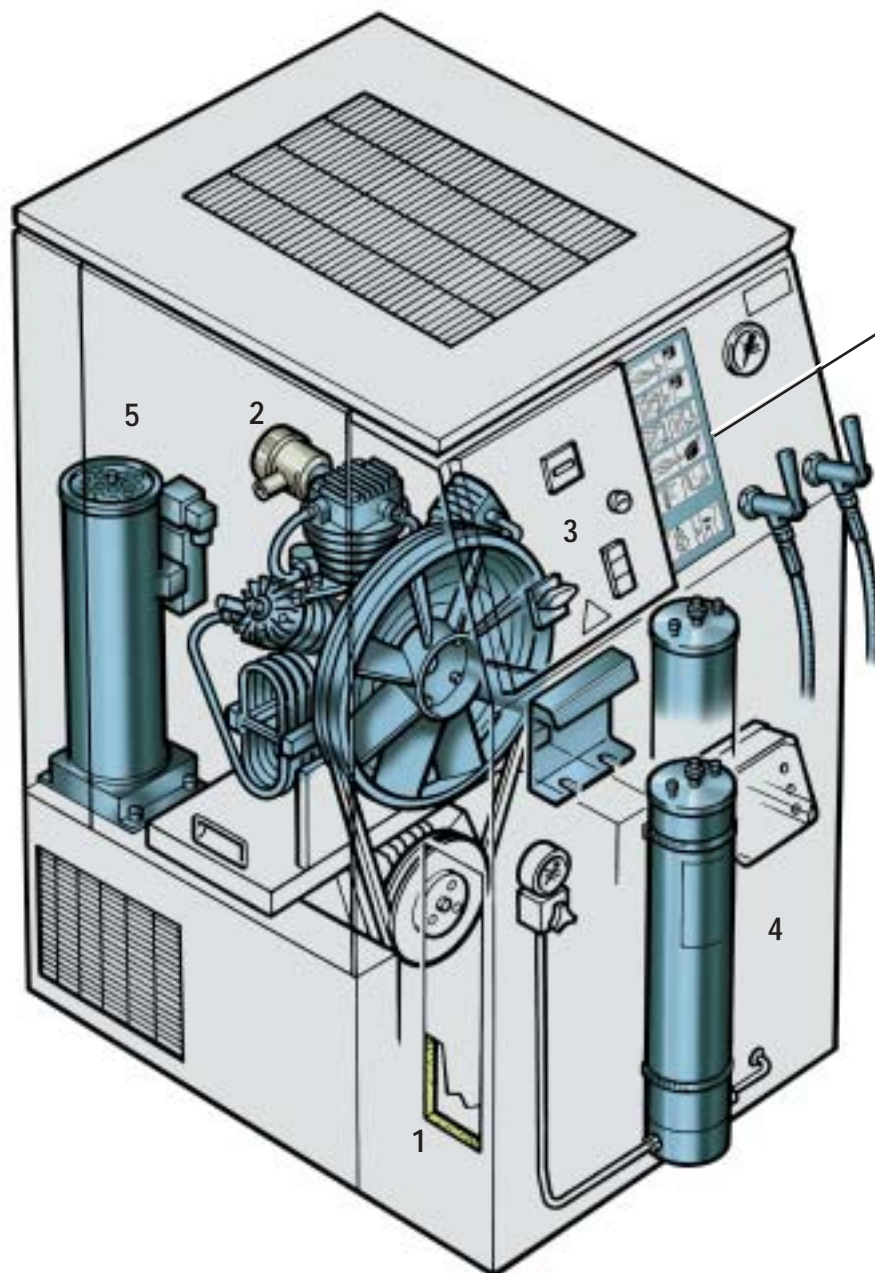

*CLEAR  
FUNCTION DISPLAY*



*SAFETY MOUNT FOR  
CHARGE LINES*

## QUIET RUNNING

The MINI-VERTICUS operates **extremely quietly**.

The housing design and special insulation materials offer outstanding silencing to **below 70 dB(A)** at 1m/3'.

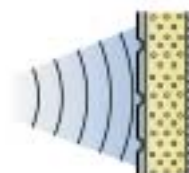

1

## COMPACT AND EASY TO MAINTAIN

The MINI-VERTICUS combines **compact dimensions** with optimum ease of maintenance. The compressor block, air filters and oil inlet connection are **easily accessed** from either side. This means that **maintenance work** can be carried out **quickly and simply**.



2

**QUALITY IN THE DETAIL****RELIABILITY AND LONGEVITY**

The gearing of the compressor blocks was made for **extreme working stress** and **continuous running**.

**Long-life, robust industrial roller bearings** with minimum friction, hardened cylinders and the new low pressure lubrication guarantee **highest economic efficiency**.

The high pressure final stage is equipped with newly developed **high-tech plastic piston rings**, which proved their outstanding wear and tear properties during several endurance tests.

The new blocks are equipped with **inter- and after coolers** made of **stainless steel**, which resist unfavourable ambient conditions for many years.

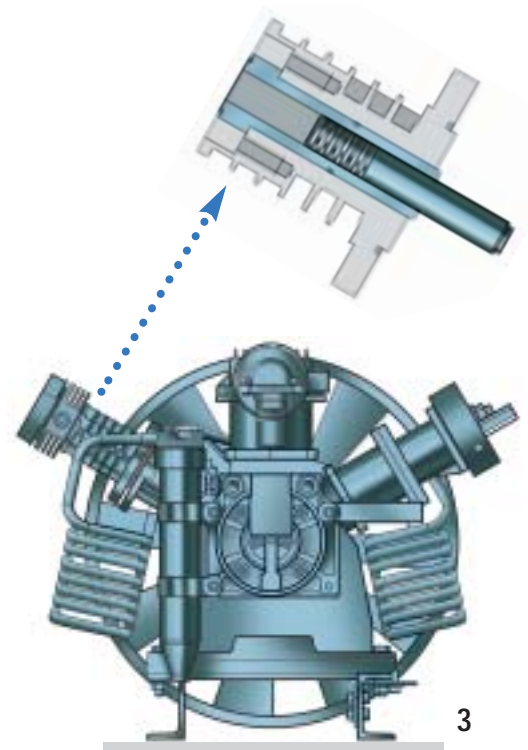

3

**SAFE**

The **P 41 FILTER SYSTEM** guarantees a safe supply of ultra-pure breathing air conforming to **better than DIN EN 12021** (former DIN 3188), BS 4275, OSHA.

**Extended filter life** offers **increased economy**.

**Optional:**

P 61 FILTER SYSTEM for larger capacity requirements.

**SECURUS SYSTEM** for **integrated filter cartridge monitoring** (for P 41 and P 61).



4

**CLEAN**

The **SSC SYSTEM** was developed for **clean, quiet condensate collection**.

The noise-insulated collection vessel is fitted with a special filter for **pure, odourless discharge air**.

The sequential automatic condensate drain permits fully **automatic operation**.



5

## THE SYSTEM

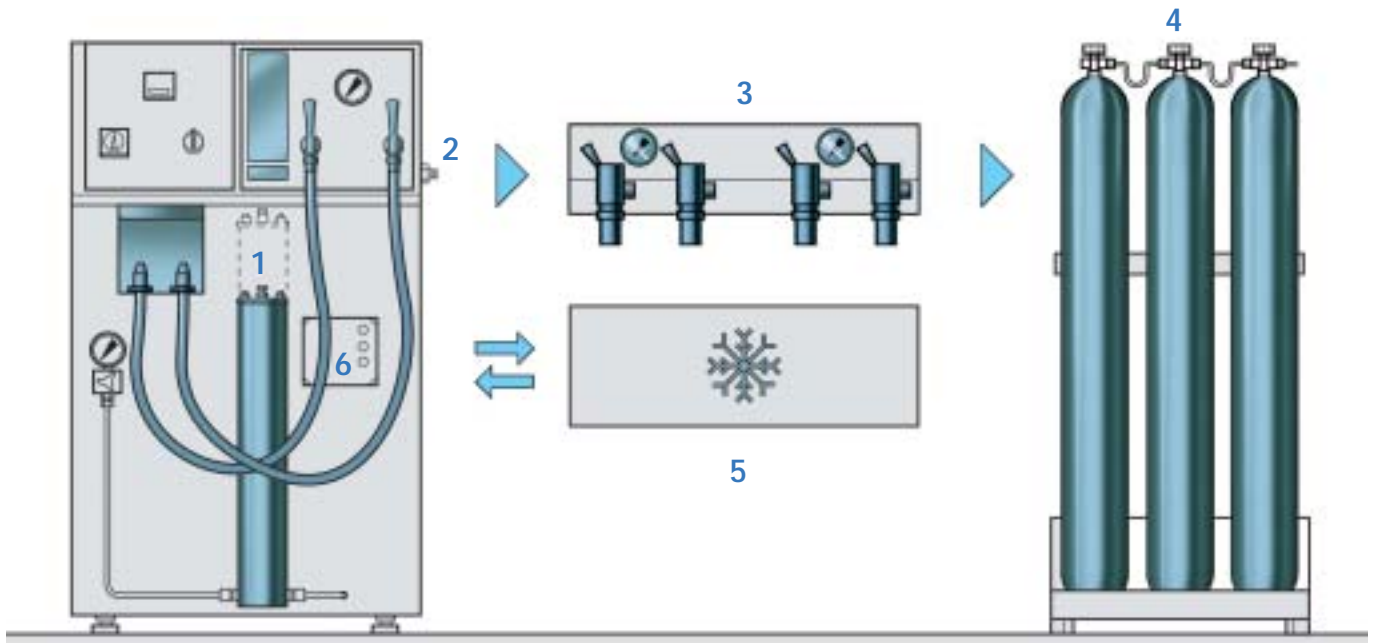

- 1 **P 61 FILTER SYSTEM** with the option of higher capacity for **longer filter life**
- 2 Charge connection for external charge strip and **air bank**
- 3 **External charge strip** for high charge requirement
- 4 Air bank
- 5 **AIR-KOOL** refrigeration drier for **multiplication of purification cartridge life**
- 6 **SECURUS air monitor** constantly **guarantees ultra-pure air**

Model	FAD		Speed rpm	Drive kW	Comp.- stages	Filter- system	Approx. dimension cm			Weight kg	Noise at 1m <sup>3</sup> / dB (A)
	l/min	m <sup>3</sup> /h					L	W	H		
MV - 100-4-2	150	9,0	1340	4	3	P41	100	70	128	255	67
MV - 120-4-2	200	12,0	1270	4	3	P41				255	67
MV - 120-5.5-2	240	14,4	1470	5,5	3	P41				260	67



### BAUER KOMPRESSOREN GmbH

P.O.BOX 710260 · D-81452 MÜNCHEN  
 DRYGALSKI-ALLEE 37 · D-81477 MÜNCHEN  
 PHONE 0049 89 78049-0  
 FAX 0049 89 78049-167  
 Internet: [www.bauer-kompressoren.de](http://www.bauer-kompressoren.de)  
 e-mail: [info@bauer-kompressoren.de](mailto:info@bauer-kompressoren.de)